

THONET

TABLE
1818

DESIGN
FORMSTELLE





DE Passend zu den Sesseln und Beistelltischen des Lounge Programms 808 haben die Designer Claudia Kleine und Jörg Kürschner von Formstelle minimalistische Bistrotische in zwei Größen entworfen. Die Produktfamilie 808 wächst somit und wird erweitert um den Tisch 1818 mit 74 cm Höhe und den großen Bruder 1828 als Stehtisch mit 105 cm. Die eleganten Bistrotische bilden das Zentrum von Kommunikationsorten und sind bestens geeignet für die Anwendungsbereiche Gastronomie und Empfang.

EN Designers Claudia Kleine and Jörg Kürschner of Formstelle have designed minimalist bistro tables in two sizes that match the armchairs and side tables of the lounge range 808. The product family 808 is growing and has been extended by the table 1818 with a height of 74 cm and its big brother 1828 as a high table with a height of 105 cm. The elegant bistro tables create space for communication and are perfectly suited for use in the restaurant and reception segments.



1818 & 1828
OBERFLÄCHE IN NUSSBAUM, BUCHE UND EICHE/
SURFACE IN WALNUT, BEECH AND OAK

DE Claudia Kleine, (geboren 1974 in München) und Jörg Kürschner (geboren 1969 in Karlsruhe, Schreiner und Möbelrestaurator) absolvierten an der Akademie der bildenden Künste in München den Studiengang Innenarchitektur. 2001 gründeten sie ebenfalls in München das Büro Formstelle, das Gestaltungsaufgaben aus den Bereichen Produktdesign, Innenarchitektur und Corporate Identity gestaltet. Für das Design-Duo spielen übergeordnete räumliche und inhaltliche Zusammenhänge eine wichtige Rolle. Die Produktgestaltung ist begleitet von einer umfangreichen Recherche und dem Experiment am Material. Eine intensive Auseinandersetzung mit Herstellungsmethoden und eine Entwicklungsbegleitung bis hin zur Serienreife ist ein wesentlicher Bestandteil der Arbeiten. Formstelle erarbeitet innovative Lösungen mit einem hohen Anspruch an konzeptionelle, technische und gestalterische Qualitäten.

EN Claudia Kleine (born 1974 in Munich) and Jörg Kürschner (born 1969 in Karlsruhe, carpenter and furniture restorer) both graduated from the Academy of Fine Arts in Munich with degrees in interior design. In 2001, they founded the office Formstelle in Munich, which undertakes design tasks in the fields of product design, interior design and corporate identity. The overarching spatial and substantial contexts play an important role for the design duo. Product design goes hand in hand with comprehensive research and material experiments. Paying special attention to production methods and accompanying products through the entire design process are an essential element of the work. Formstelle develops innovative solutions with a high standard of conceptual, technological and design quality.



FORMSTELLE
CLAUDIA KLEINE; JÖRG KÜRSCHNER

TABLE 1818/1828



1818
GESTELL FLACHSTAHL,
TISCHPLATTE ECHTHOLZFURNIER ODER
SCHICHTSTOFF/FRAME FLAT STEEL, TABLETOP
REAL WOOD VENEER OR LAMINATE



1828
GESTELL FLACHSTAHL,
TISCHPLATTE ECHTHOLZFURNIER ODER
SCHICHTSTOFF/FRAME FLAT STEEL, TABLETOP
REAL WOOD VENEER OR LAMINATE



MATERIALIEN/MATERIALS

ALLE MATERIALIEN AUF ANFRAGE/
ALL MATERIALS ON REQUEST

GESTELL/FRAME



FLACHSTAHL
EDELSTAHLÖPTIK/
FLAT STEEL STAINLESS
STEEL DESIGN



RAL 9005
TIEFSCHWARZ/
DEEP BLACK

HOLZ/WOOD



BUCHHE/
BEECH



ESCHE/
ASH



EICHE/
OAK



NUSSBAUM/
WALNUT

SCHICHTSTOFF/LAMINATE



HELLGRAU/
LIGHT GREY



WEISS/
WHITE



SCHWARZ/
BLACK

BEIZE/STAIN



TP 17
BUCHHE NATUR/
BEECH NATURE



TP 107
AUFGEHELLT/
LIGHTENED



TP 89
DUNKELBRAUN/
DARK BROWN



TP 44
KIRSCHBAUM/
CHERRY TREE



TP 34
MAHAGONI/
MAHOGANY



TP 29
SCHWARZ/
BLACK



TP 24
NUSSBAUM/
WALNUT

PLATTENAUSFÜHRUNGEN



ECKEN GERADE, KANTEN GERADE/
STRAIGHT CORNERS, STRAIGHT EDGES



ECKEN GERADE, KANTEN UNTERSEITIG
ABGESCHRÄGT/STRAIGHT CORNERS,
EDGES BEVELLED ON THE BOTTOM SIDE



ECKEN GERUNDET, KANTEN GERADE/
ROUNDED CORNERS, STRAIGHT EDGES



ECKEN GERUNDET, KANTEN UNTERSEITIG
ABGESCHRÄGT/ROUNDED CORNERS,
EDGES BEVELLED ON THE BOTTOM SIDE

MASSE/MEASUREMENTS

1818

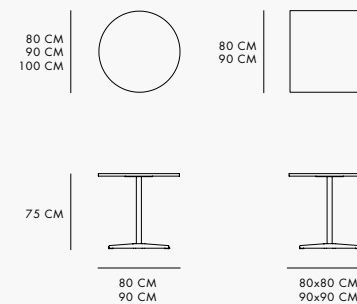

1828

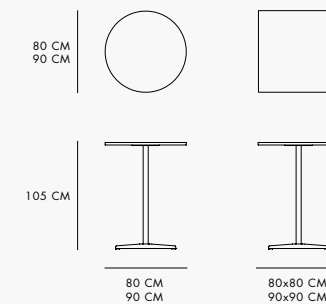

THONET

CREDITS

Photos: Hartig & Thiel, Silke Floren

Concept: Lambi Office

Layout: Thonet GmbH

Text: Thonet GmbH,

Claudia Neumann Communication GmbH

Translation: proidioma Sprachdienstleistungen



TABLE 1818 DE/EN 02.23

THONET GMBH
MICHAEL-THONET-STRASSE 1
35066 FRANKENBERG/EDER
DEUTSCHLAND/GERMANY

T: +49 6451 508-0
F: +49 6451 508-108
E: INFO@THONET.DE
WWW.THONET.DE